



**Burkert Fluid Control Systems**

**USA**

US Headquarters  
11425 Mt. Holly-Huntersville Road  
Huntersville, NC 28078

Phone: 1-800-325-1405

Fax: 949-223-3198

[marketing-usa@burkert.com](mailto:marketing-usa@burkert.com)  
[www.burkert-usa.com](http://www.burkert-usa.com)

**Canada**

5002 South Service Road  
Burlington, Ontario L7L 5Y7

Phone: 905-632-3033

Fax: 905-632-3833

[sales.ca@burkert.com](mailto:sales.ca@burkert.com)  
[www.burkert.ca](http://www.burkert.ca)



# Dialysis Solutions



**bürkert**  
FLUID CONTROL SYSTEMS





# Hemodialysis

The classic hemodialysis is a clinical process for patients with failed or damaged kidney function, by which toxins are filtered out of the blood. Number one priority is reliability and the safety of the patient. Development of a new dialysis machine means designing the device to be efficient, economical and having a long service life.

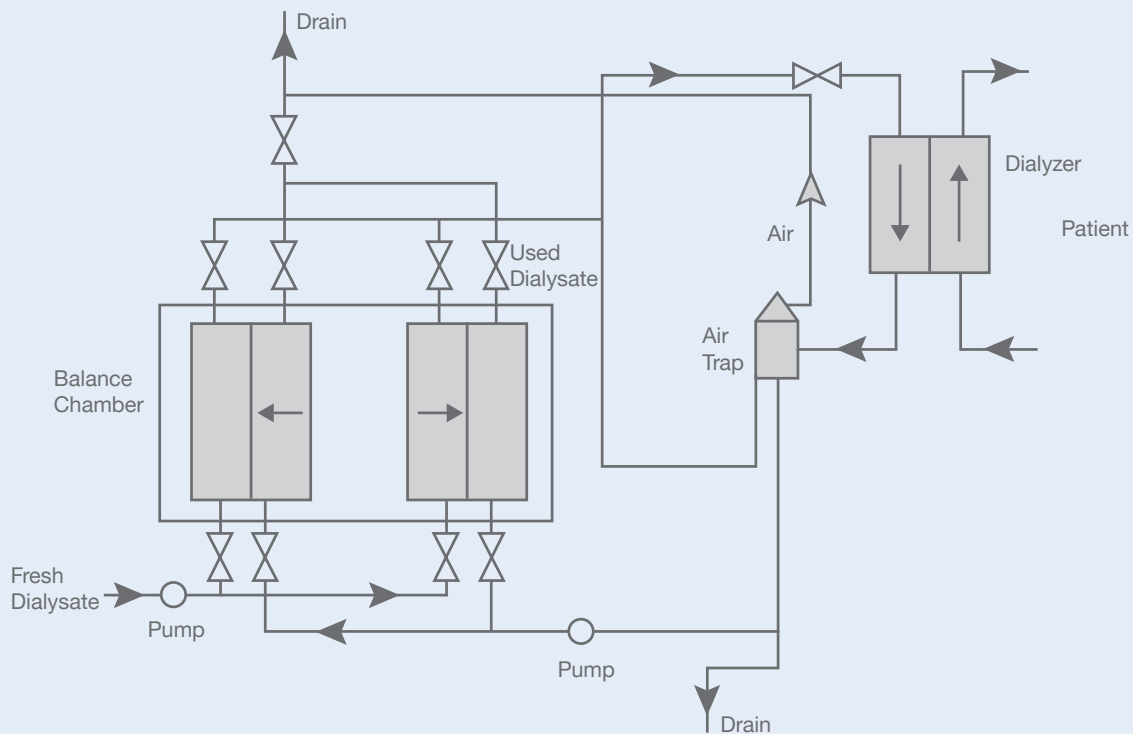

## Type 6724 – Whisper Valve with media separation

Type 6724 is a 8.9 mm, 2/2 or 3/2-way valve that features an extremely compact design with usually high efficiency for its size. Innovative actuator technology enables virtually silent switching of the valve, which makes the WhisperValve unique in its markets. Thanks to the modular structure and the range of available materials this valve is almost universal.



## Type 6628 – Rocker Valve

Type 6628 is a 22 mm, 3/2-way valve that controls high flow rates. The established rocker technology is characterized through its reliable sealing of the valve seat with full back pressure tightness. Cross contamination is eliminated with its good rinsing capability, and the low internal volume maximizes the use of medium.



## Type 0330 – Pivoted Armature Valve

Type 0330 is especially suitable for the control of aggressive or waste media, which require a separation of medium and actuator. Depending on the orifice, the valve is suitable for pressures up to 16 bar (232 psi), and an orifice of up to 5 mm allows for high flow rates.

# Automatic Peritoneal Dialysis

The automatic peritoneal dialysis allows patients to be flexible and have more freedom in life. The dialysis process is done using the patients peritoneum in the abdomen, and can be done by the patients at home or even at night while they sleep. Therefore, the reliability of the device is extremely important as well as the compact, portable design and quiet operation to give patients the necessary rest.

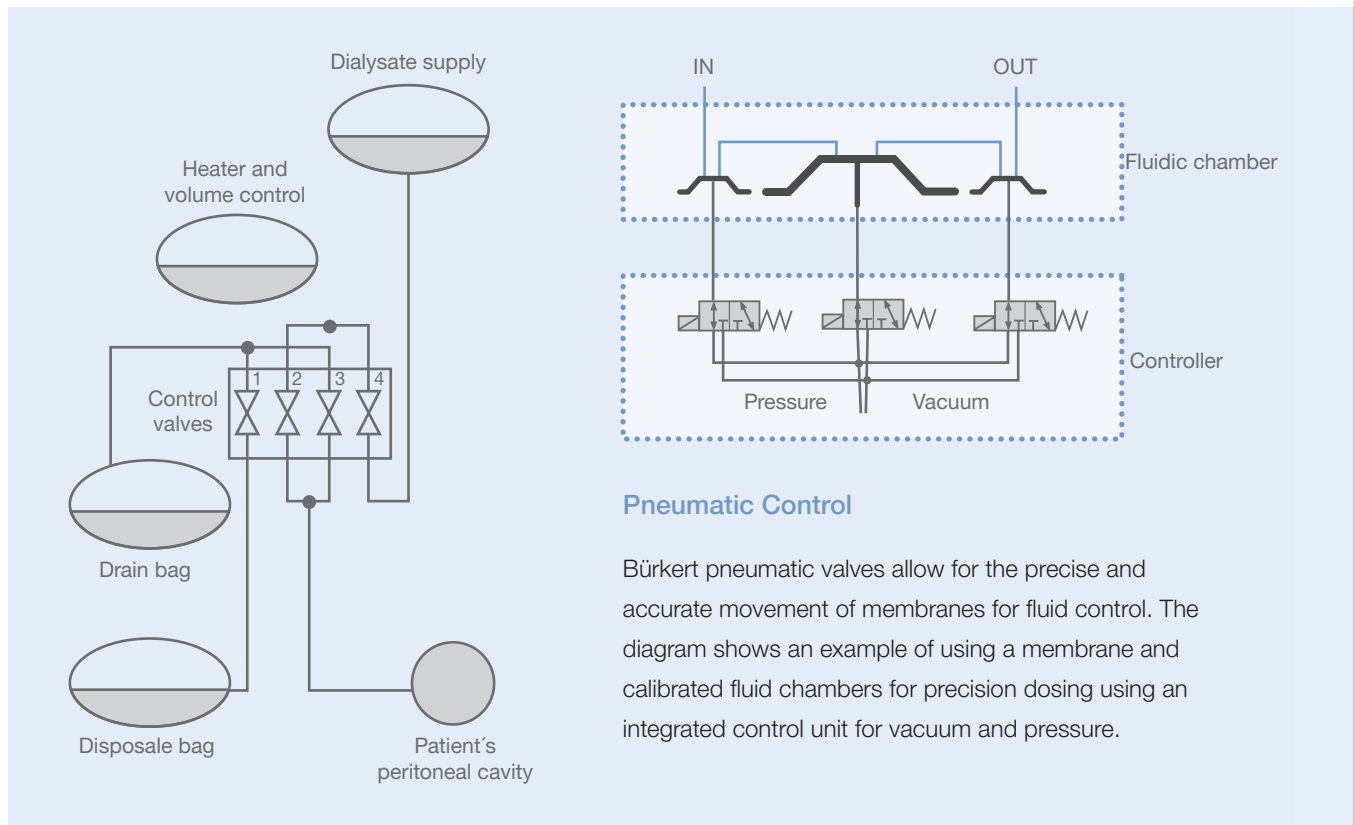

## Pneumatic Control

Bürkert pneumatic valves allow for the precise and accurate movement of membranes for fluid control. The diagram shows an example of using a membrane and calibrated fluid chambers for precision dosing using an integrated control unit for vacuum and pressure.



## Type 6144 - Flipper Valve

The medium separated Type 6144 is especially suitable for pneumatic applications. Its compact design makes it ideal for mobile or portable devices such as the automatic peritoneal dialysis machine. The valve boasts a particularly long service life of more than 500 million cycles for greater reliability and safety for the patient.



## Type 6164 - Cartridge Solenoid Valve

With an outer diameter of 9 mm and a height of 28 mm, Type 6164 is exceptionally compact and light. Thanks to the new cartridge design, easy "plug-and-play" capabilities allow the valve to be installed in even the smallest spaces, so you can design your dialysis machine conveniently compact and easily portable. Its uniquely quiet switching, allows the patient to easily rest during treatment.

# Continuous Reliability in each Process Step

Used in dialysis for years, Bürkert valves have proven to be safe, reliable and efficient, saving you cost with no maintenance or replacement requirements. The design of our micro valves includes media separation, protecting your medium as well as your valve. With high temperature and chemically demanding disinfection processes, you want high functional safety and reliability in the product. As your reliable partner, we can assist you with the documentation requirements for your validation process.

	EPDM	FKM	FFKM	PEEK	PVDF
Steam (up to 130°C)	+	+	+	+	+
Peracetic Acid (6%)	+	+	+		
Citric Acid	+	+	+	+	+

+ Resistant; little or no effect on material

## Available Material

With a wide range of available sealing and body material, our products are guaranteed to perform under demanding conditions during normal operation or disinfection cycles.



### Type 2853 – Solenoid Control Valve with Media Isolation

Type 2853 is a unique control valve in that the solenoid is isolated from the flow path, protecting both the medium and the valve. Thanks to this media isolation, the life cycle is increased and the use of aggressive media is possible.



### Type 0290 – Servo-assisted 2/2-way Diaphragm Valve

With available orifice sizes DN 12 - 50mm, Type 0290 controls higher flow rates and finds perfect use in the water treatment process of your dialysis machine. Various diaphragm material combinations and the stainless steel housing allow for the safe use in dialysis applications.

# Customized Solutions

We specialize in:

- consulting, design and fluid system integration
- complete fluidic systems, sub-assemblies and high quality products
- manifolds: machined, molded, bonded, sandwiched from all materials plastic and metal
- machined and molded parts

Integration includes:

- valves, pumps and sensors
- fittings, needles and tubing
- electronics and connectors

